

# novopress

## Mastering Innovations

Creating competitive advantages through innovation. That's the key driver for our unique solutions in the electrical industry.

Efficient busbar manufacturing lines and innovative dieless crimping tools, provide the competitive edge for our global customers.

**novopress**

## HSBL-2 Cutting Tool 160

For stationary cutting applications up to 160 x 13 mm (6" x 1/2"), the HSBL-2 Cutting Tool 160, is the ideal choice for professional, stationary busbar production.

State of the art operator safety and additional accessories like centering device and conveyor systems, are making the HSBL-2 Cutting Tool 160, an integrated part of our busbar production lines.

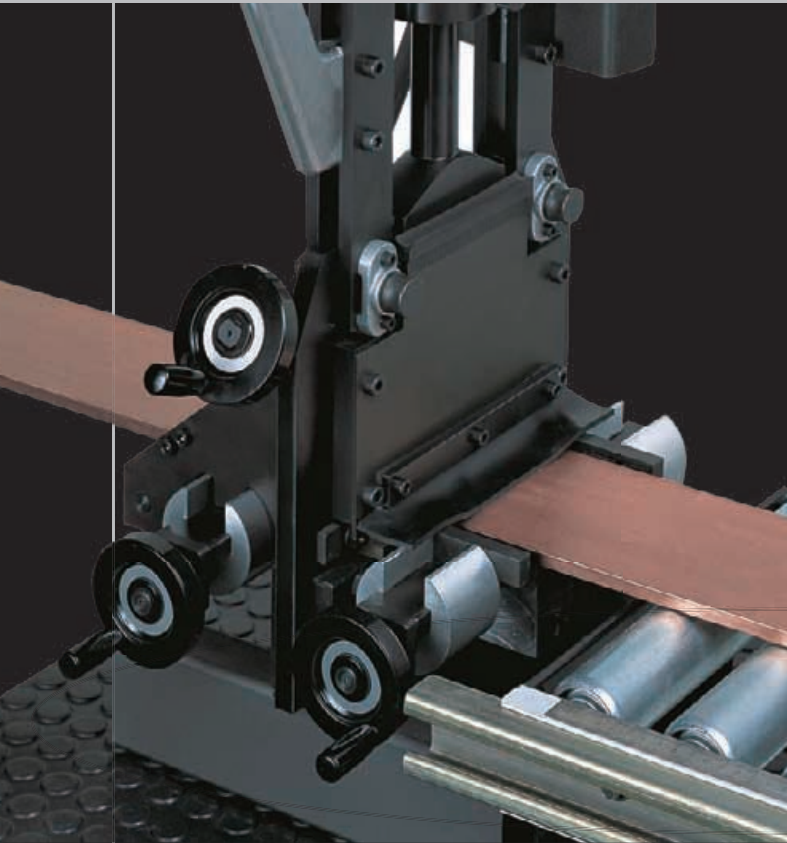

Cutting Tool including two fixing vices and conveyor.

Technical Data		Ref. 7020
Height	940 mm	(incl. work-cylinder)
Depth	310 mm	
Width	375 mm	
Weight	22 kg	
Operating pressure	150 bar	
Force	150 KN	
Cutting perf. max.	160 x 13 mm	250 N/mm <sup>2</sup>
Cycle time	15 sec.	

Order Numbers	
O/N 7020	Cutting tool. 160 x 13 mm
O/N 7030	Centering vice for O/N 7020
O/N 6990	Length stop for O/N 7020

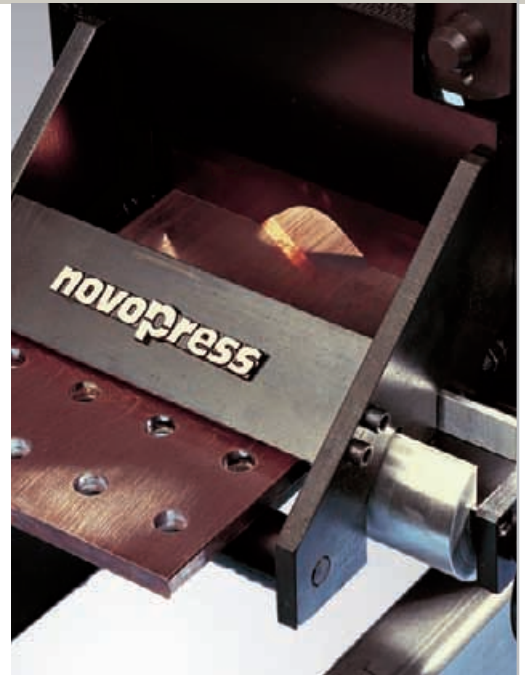

HSBL-2 Cutting Tool 160 x 13 mm (6" x 1/2")

## HSBL-2 Punching Tool 160

For stationary punching applications up to 160 x 13 mm (6" x 1/2"), the HSBL-2 Punching Tool 160, is the ideal choice for stationary busbar production. State of the art operator safety and the additional X-Y positioning device will vanquish the need for pre-measuring and center marking on your busbar. Excellent punching quality with round, elongated and square dies, are making the HSBL-2 Cutting Tool 160 the ideal option for small and medium work shops.

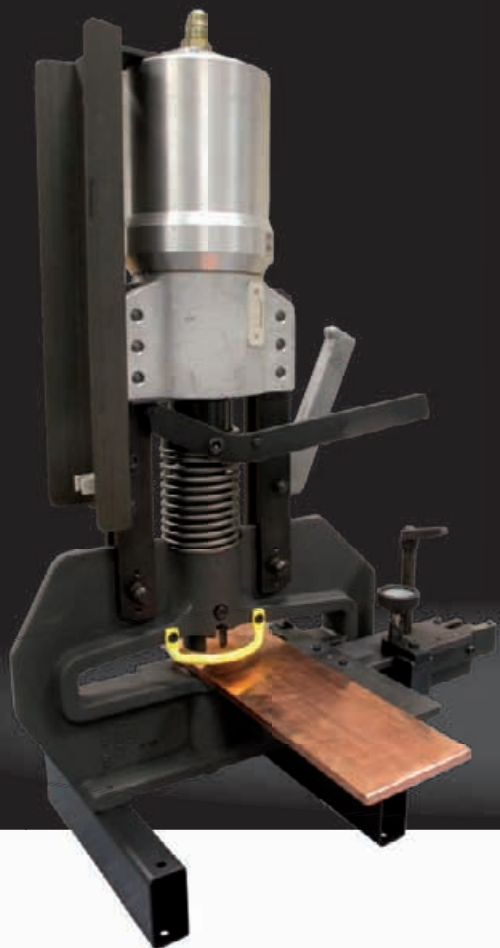

### Technical Data Ref. 34243

Height	900 mm (incl. work-cylinder)
Depth	460 mm
Width	600 mm
Weight	38.2 kg
Operating pressure	150 bar
Force	150 KN
Cutting perf. max.	160 x 13 mm 250 N/mm <sup>2</sup>
Cycle time	3 sec.*

\* Busbar 120 x 10 mm  
Recommended power pack: HA 4.

### Order Numbers

O/N 34243	Punching tool 160 x 13 mm incl. X-Y positioning device
O/N 7050	Punching tool 160 x 13 mm
O/N 7190	X-Y stop device for O/N 7050

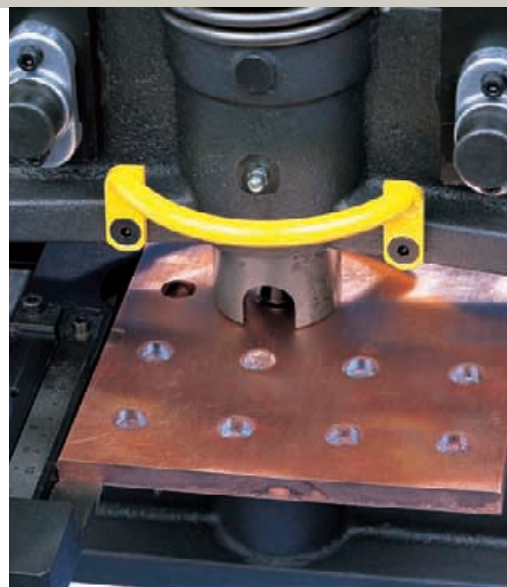

Punching tool 160 x 13 mm (O/N 7050)



## The digital bending bench **BGD-5eco**

The BGD-5eco sets a new standard for bus bar bending with outstanding precision and speed at economical prices. No other bending machine will match its range of features and performance at low entry price levels. Equipped with the essential - Digital Angle Encoder - the BGD-5eco offers unsurpassed simplicity and control with full automatic spring back compensation and bending accuracy to 0.2 degrees. Consequently it will vanquish any need for trial bends and significantly reduce cost on faulty bend busbars. On top, the digital stroke encoder minimizes idle movement for the absolute shortest cycle times. Additional accessories like step or edge benders, are also easy and precisely controlled by the digital stroke encoder.

The new integrated hydraulic power pack takes bending speeds to new levels - 11.5 seconds\* - for a finished 90 degree bend including full automatic spring back compensation.

### Advantages

- Unsurpassed bending features at economic price.
- Digital Angle Encoder with precision to 0.2 degrees.
- Full automatic spring back compensation.
- No trial bends. No set up times.
- Digital Stroke Encoder for minimum cycle times.
- Supplied with built in high performance 3-phase power pack.
- Optional step- and edge bending tools, for special bending applications.
- Tight L-, U- and Z- bends possible.
- Mobile machine on wheels for ease of use.

**novopress**

## Digital bending bench **BGD-5eco**

Technical Data	Ref. 42380
Depth	950 mm
Width	830 mm
Height	1.330 mm
Weight	170 kg
Operating Pressure	200 bar
Force	180 kN
Bending capacity max.	160 x 13 mm (6" x 1/2")
Bending radius adaptors	7.5, 10, 15 mm
Power rating	0.75 kW
Voltage	400 V 3-/50 Hz.
Oil flow	3.6 l/min.
Cycle time*	11.5 sec.
Cycle time** (repeat operation)	9.4 sec.
Minimum L-Bend	25 mm
Minimum U-Bend	60 mm
Minimum Z-Bend	70 mm

\* 90° bend, 120 x 10 mm busbar size, return stroke incl. full automatic spring back compensation.

\*\* 90° bend, 120 x 10 mm busbar size repeated operation.



We reserve the right to make technical modifications.

**novopress**

Novopress GmbH & Co. KG  
Scharnhorststraße 1 · D-41460 Neuss  
Tel.: +49(0)2131-288-0 · Fax: +49(0)2131-288-55  
www.novopress.de · E-Mail: verkauf@novopress.de

S6-GB/12.09-0

## Hydraulic Power Pack HA 3

Leaders when it comes to switchgear manufacturing. Novopress hydraulic power packs are designed to operate at a low 150 bar over a wide range of applications. This design combines the clear advantages of increased work safety, and long service life for the tool and its attached devices. In addition, these hydraulic power packs are a byword for the high quality associated with all Novopress products.



Technical Data		Ref. 32530
Drive	230 V - 750 W, 4 A	
Weight	26 kg	
Height	550 mm	
Length	270 mm	
Width	260 mm	
Oil capacity	5.5 l	
Operation S 3	S 1=	
Safety class	IP 55	
Hydraulic hose	2.5 m	
Operating pressure	150 bar (2.200 psi)	
Oil flow	4.0 l/min.	

Order Numbers	
O/N 32530	Power Pack HA 3
O/N 33340	Power Pack HA 3 incl. 24 V controls

For heavy duty applications and continuous production, the HA 3 Power Pack, is the professional choice.

With a high performance drive and extended oil volume, the HA 3 is the ideal power pack for demanding busbar production, and/or continuous cable assembly. Available with or without 24 V controls for hand operated crimping tools.

## Ref. 41431 HSBL-2 Basic System

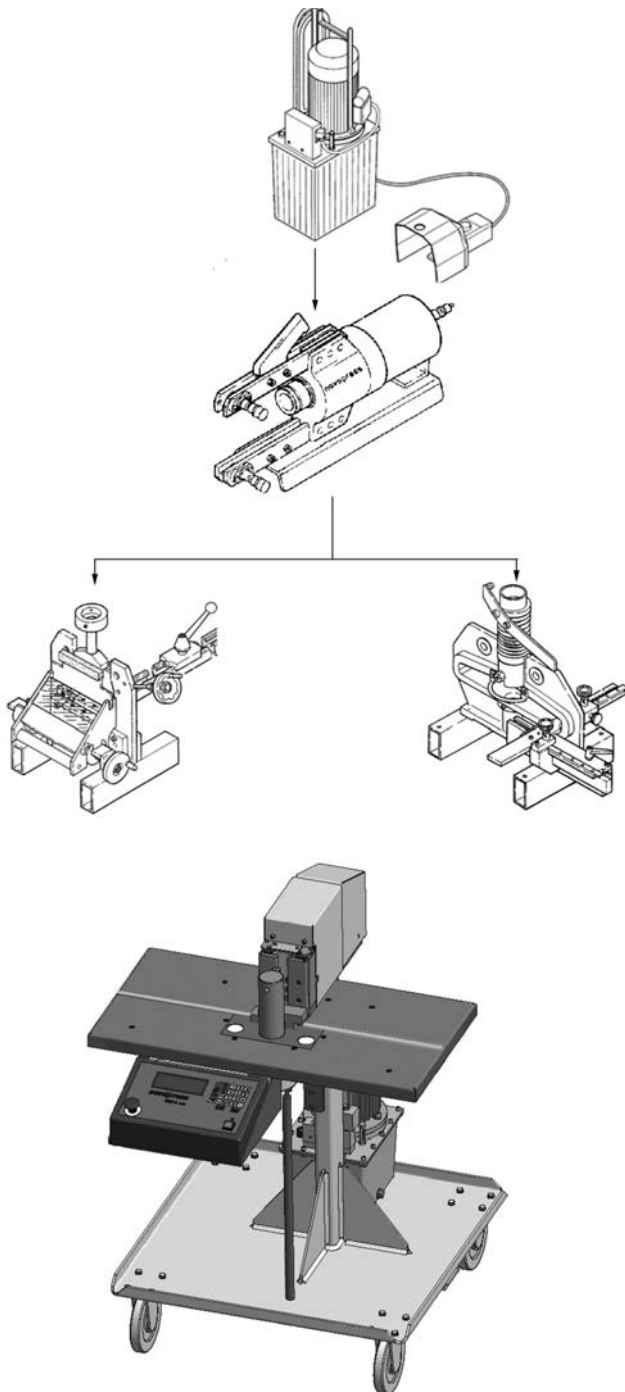

Ref. 32530 HA3 Power Pack

Ref. 2420 HSBL-2 Work cylinder

Ref. 7020 Cutting Tool 160

Ref. 7030 Centering Device to 7020

Ref. 6990 Stop Device 2000mm

Ref. 34243 Punching Tool 160 incl. X-Y Device

Ref. 200090 Die set 9.0mm

Ref. 200110 Die set 11.0mm

Ref. 200140 Die set 14.0mm

Ref. 42380 Bending bench BGD-5eco

BGD-5eco front

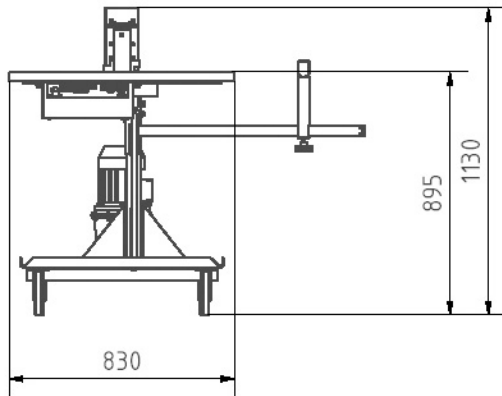

BGD-5eco top

