

# novopress

## Mastering Innovations

Creating competitive advantages through innovation. That's the key driver for our unique solutions in the electrical industry.

Efficient busbar manufacturing lines and innovative dieless crimping tools, provide the competitive edge for our global customers.

**novopress**

## HSBL-2 Cutting Tool 160

For stationary cutting applications up to 160 x 13 mm (6" x 1/2"), the HSBL-2 Cutting Tool 160, is the ideal choice for professional, stationary busbar production.

State of the art operator safety and additional accessories like centering device and conveyor systems, are making the HSBL-2 Cutting Tool 160, an integrated part of our busbar production lines.

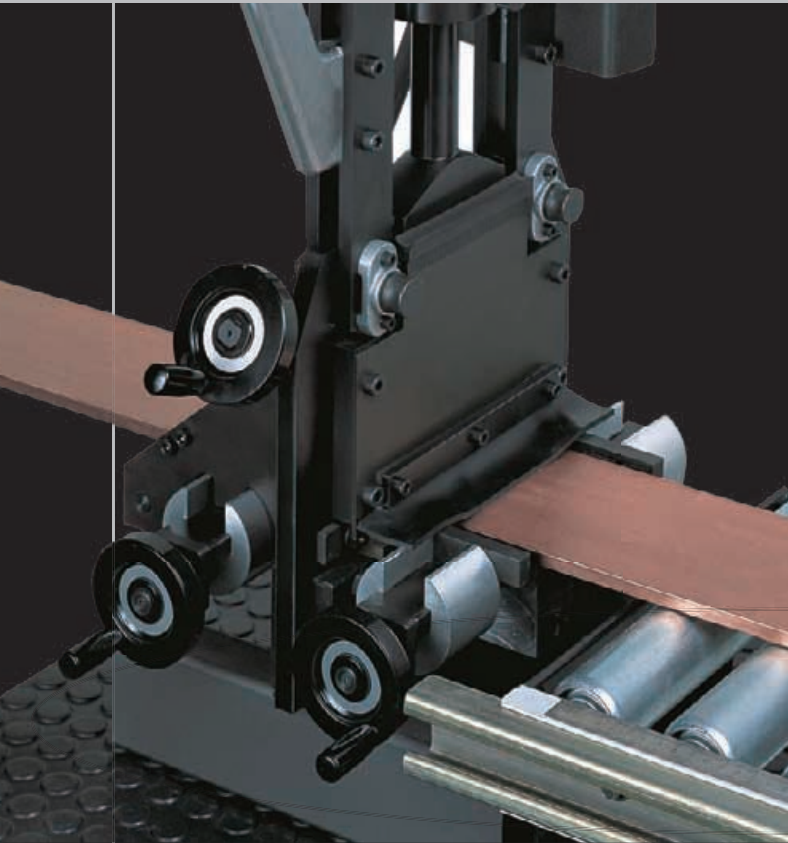

Cutting Tool including two fixing vices and conveyor.

Technical Data		Ref. 7020
Height	940 mm	(incl. work-cylinder)
Depth	310 mm	
Width	375 mm	
Weight	22 kg	
Operating pressure	150 bar	
Force	150 KN	
Cutting perf. max.	160 x 13 mm	250 N/mm <sup>2</sup>
Cycle time	15 sec.	

Order Numbers	
O/N 7020	Cutting tool. 160 x 13 mm
O/N 7030	Centering vice for O/N 7020
O/N 6990	Length stop for O/N 7020



HSBL-2 Cutting Tool 160 x 13 mm (6" x 1/2")



## A new class of Performance

With the brand-new “DigiPunch 160”, Novopress offers a new class of busbar punching performance for medium-sized enterprises. Wherever ordinary manual punches are insufficient and CNC-controlled machines are too costly, the new “DigiPunch 160” is the ideal mid-size solution. It reduces manufacturing time and cost significantly compared to manual punches at a very modest investment compared to CNC-punches. The very practical configuration with digital metering in X/Y axis and complete conveyors, enables a very efficient and flexible busbar manufacturing.

### Advantages

- Significantly reduced manufacturing cost on medium to medium-large output volume.
- Optimized and speedy work flow through integrated conveyor system and work-bench.
- No programming or preparatory work required, very short set-up times.
- Fast and stepless positioning of busbars in X and Y axis, with 0.5 mm accuracy.
- Switching from absolute- to chain-measurement for fast and easy progressive punching.

## HSBL-2 DigiPunch 160

### Technical Data

All necessary components except hydr. power pack and work cylinder are included in delivery. For operation only a regular 110V/60Hz or 220V/50Hz power source is needed. The LCD measuring system works on a permanent battery basis. Possible hydr. Power Packs: HA 1 - ES, HA 3 and HA 4.

Technical Data		Ref. 40800
Length	4.300 mm	
Width	550 mm	
Height	1.900 mm	
Weight	170 kg	
Operating pressure	150 bar (2.200 psi)	
Force	150 KN	

### Ref. Numbers

Ref. No. 40800	HSBL-2 DigiPunch 160 (containing punch with digital measuring system, adjustable work-bench, 2 x 2 m conveyor system, supports for conveyors)
----------------	--

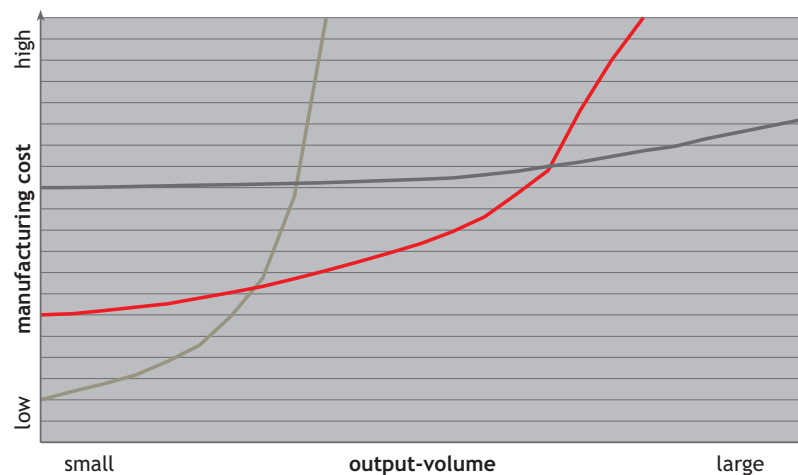

Fast - productive - competitive

- DigiPunch 160
- Manual punching machine
- CNC punching machine

### New progressive punching dies

Also the punching dies are new designed and further reduce manufacturing cost. Punch and die are interchangeable by quick clamp mechanism within 20 sec.

The solid toolholder enables progressive punching for oblong and slotted wholes. Switching from absolute to chain-measurement, offers fast progressive punching without extra calculating.

Last but not least we offer a wide range of standard dies for round-, oblong- and square punching, especially matched with the needs of the electrical industry.

- Solid toolholder for progressive punching of oblong and slotted wholes.
- Quick clamping offers fast and easy die change within 20 seconds. Set-up times are reduced, no tools necessary.
- Large assortment of standard dies for round-, oblong- and square punching.



We reserve the right to make technical modifications.

**novopress**

Novopress GmbH & Co. KG  
Scharnhorststraße 1 fi D-41460 Neuss  
Tel.: +49(0)2131-288-0 fi Fax: +49(0)2131-288-55  
www.novopress.de fi E-Mail: verkauf@novopress.de



## The digital bending bench **BGD-5eco**

The BGD-5eco sets a new standard for bus bar bending with outstanding precision and speed at economical prices. No other bending machine will match its range of features and performance at low entry price levels. Equipped with the essential - Digital Angle Encoder - the BGD-5eco offers unsurpassed simplicity and control with full automatic spring back compensation and bending accuracy to 0.2 degrees. Consequently it will vanquish any need for trial bends and significantly reduce cost on faulty bend busbars. On top, the digital stroke encoder minimizes idle movement for the absolute shortest cycle times. Additional accessories like step or edge benders, are also easy and precisely controlled by the digital stroke encoder.

The new integrated hydraulic power pack takes bending speeds to new levels - 11.5 seconds\* - for a finished 90 degree bend including full automatic spring back compensation.

### Advantages

- Unsurpassed bending features at economic price.
- Digital Angle Encoder with precision to 0.2 degrees.
- Full automatic spring back compensation.
- No trial bends. No set up times.
- Digital Stroke Encoder for minimum cycle times.
- Supplied with built in high performance 3-phase power pack.
- Optional step- and edge bending tools, for special bending applications.
- Tight L-, U- and Z- bends possible.
- Mobile machine on wheels for ease of use.

**novopress**

## Digital bending bench **BGD-5eco**

Technical Data		Ref. 42380
Depth	950 mm	
Width	830 mm	
Height	1.330 mm	
Weight	170 kg	
Operating Pressure	200 bar	
Force	180 KN	
Bending capacity max.	160 x 13 mm (6 · x 1/2 ·)	
Bending radius adaptors	7.5, 10, 15 mm	
Power rating	0.75 kW	
Voltage	400 V 3-/50 Hz.	
Oil ow	3.6 l/min.	
Cycle time*	11.5 sec.	
Cycle time** (repeat operation)	9.4 sec.	
Minimum L-Bend	25 mm	
Minimum U-Bend	60 mm	
Minimum Z-Bend	70 mm	

\* 90° bend, 120 x 10 mm busbar size, return stroke incl. full automatic spring back compensation.

\*\* 90° bend, 120 x 10 mm busbar size repeated operation.



We reserve the right to make technical modifications.

**novopress**

Novopress GmbH & Co. KG  
 Scharnhorststraße 1 fi D-41460 Neuss  
 Tel.: +49(0)2131-288-0 fi Fax: +49(0)2131-288-55  
 www.novopress.de fi E-Mail: verkauf@novopress.de

## Hydraulic Power Pack HA 3

Leaders when it comes to switchgear manufacturing. Novopress hydraulic power packs are designed to operate at a low 150 bar over a wide range of applications. This design combines the clear advantages of increased work safety, and long service life for the tool and its attached devices. In addition, these hydraulic power packs are a byword for the high quality associated with all Novopress products.



Technical Data		Ref. 32530
Drive	230 V - 750 W, 4 A	
Weight	26 kg	
Height	550 mm	
Length	270 mm	
Width	260 mm	
Oil capacity	5.5 l	
Operation S 3	S 1=	
Safety class	IP 55	
Hydraulic hose	2.5 m	
Operating pressure	150 bar (2.200 psi)	
Oil ow	4.0 l/min.	

Order Numbers	
O/N 32530	Power Pack HA 3
O/N 33340	Power Pack HA 3 incl. 24 V controls

For heavy duty applications and continuous production, the HA 3 Power Pack, is the professional choice.

With a high performance drive and extended oil volume, the HA 3 is the ideal power pack for demanding busbar production, and/or continuous cable assembly. Available with or without 24 V controls for hand operated crimping tools.

## Ref. 40742 HSBL-2 Professional System 1

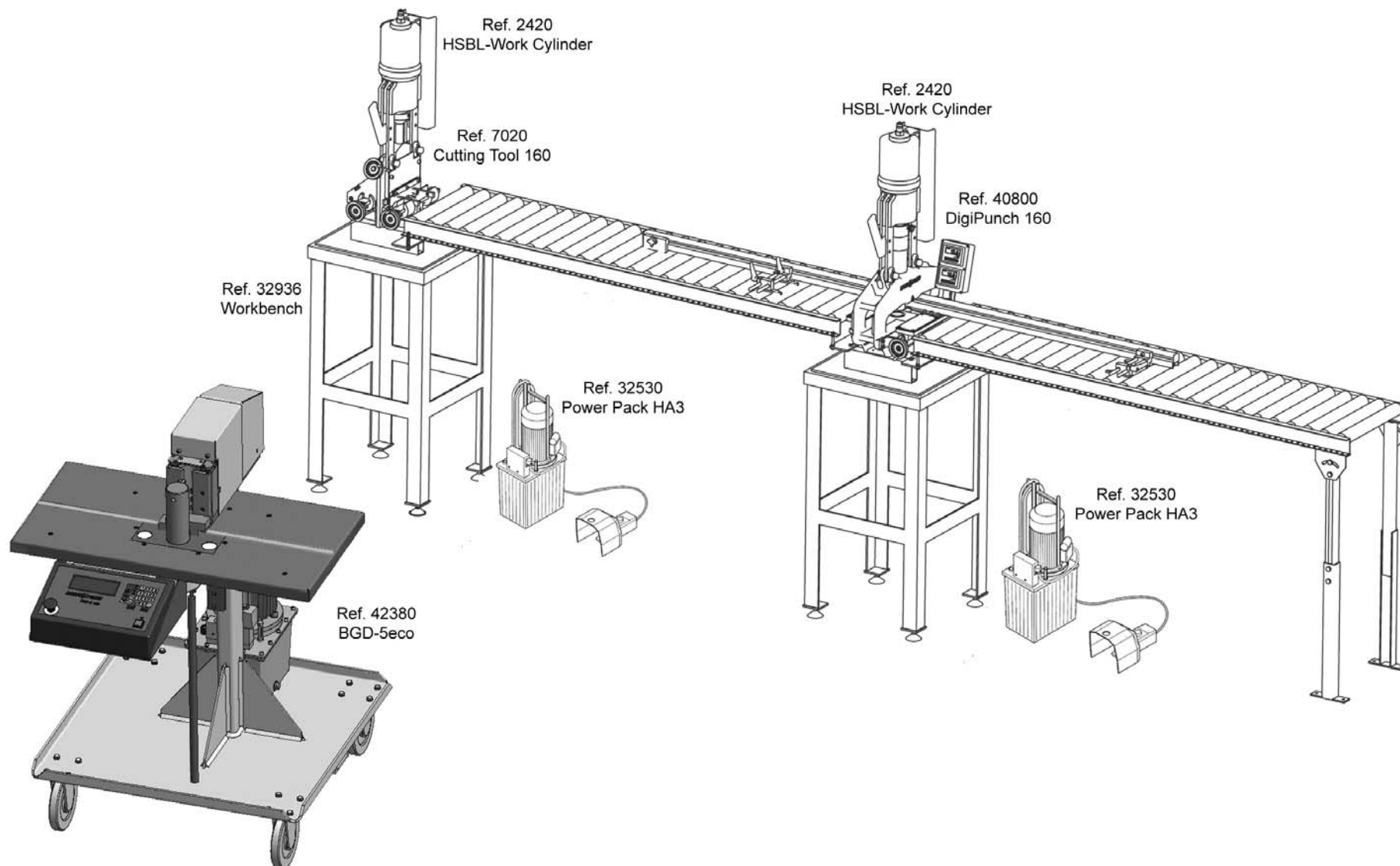

Ref. 40742 Professional System 1.  
Space requirements "in line setup"

cutting station

DigiPunch 160

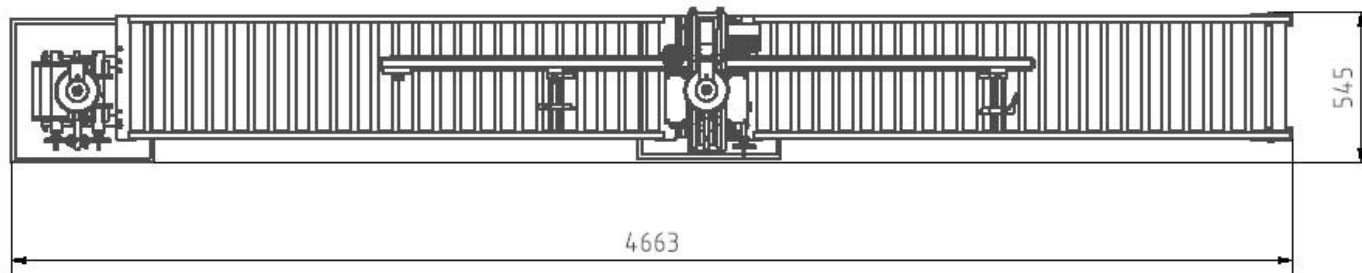

BGD-5eco front

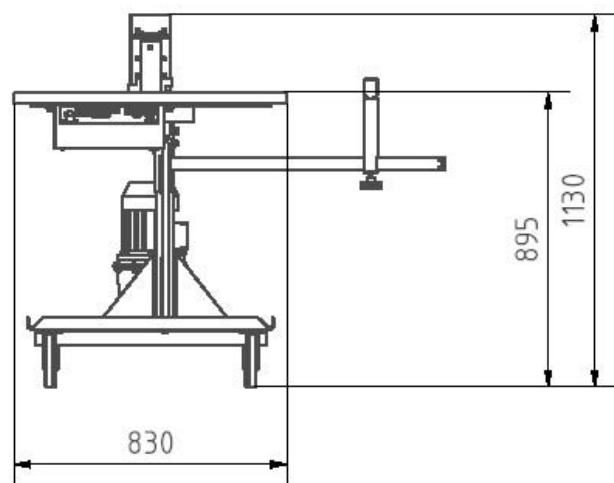

BGD-5eco top

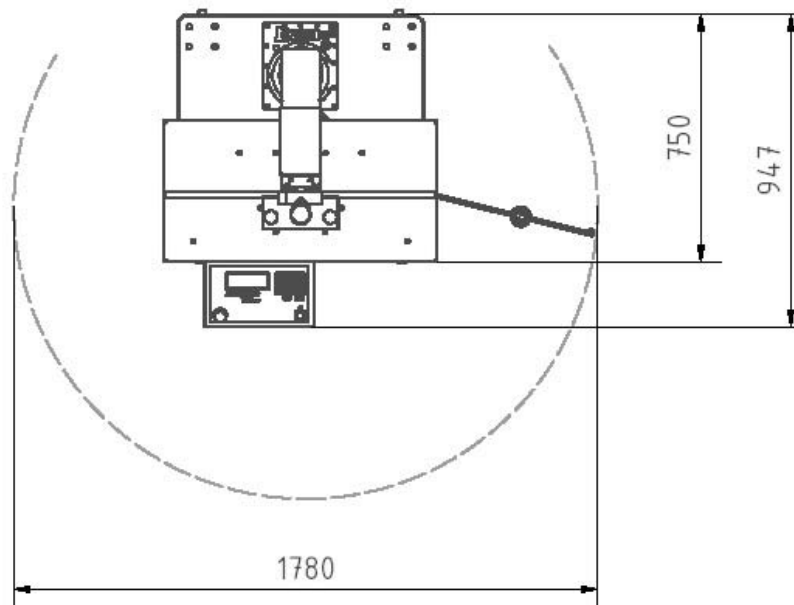

Ref. 40742 Professional System 1.  
Space requirements "parallel setup"

cutting station

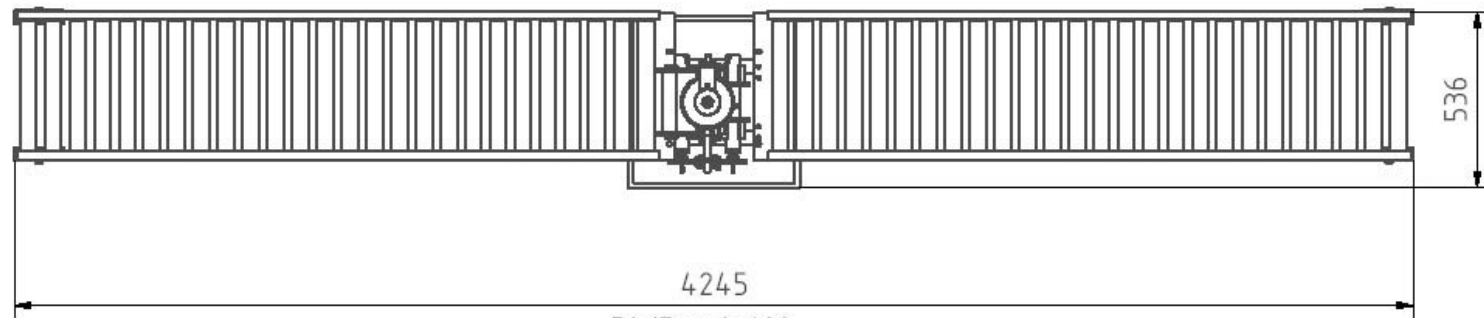

DigiPunch 160

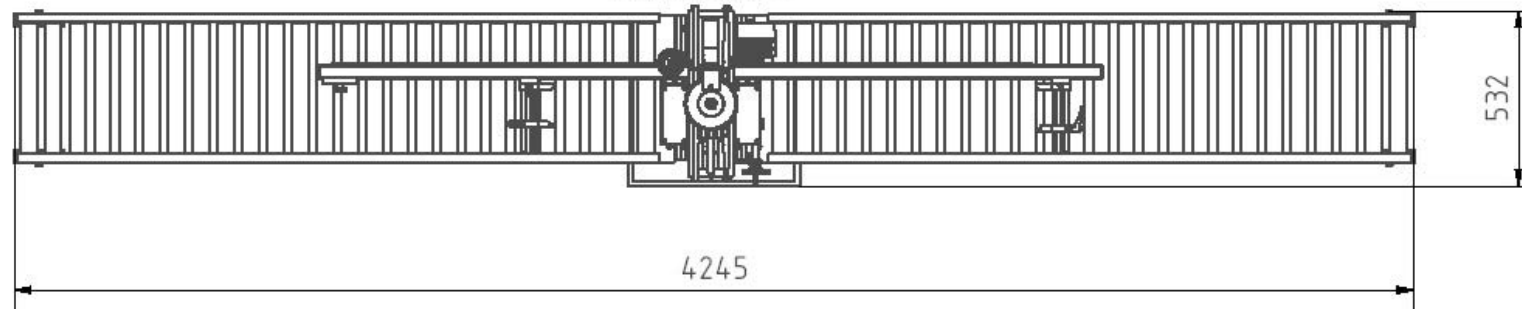

BGD-5eco front

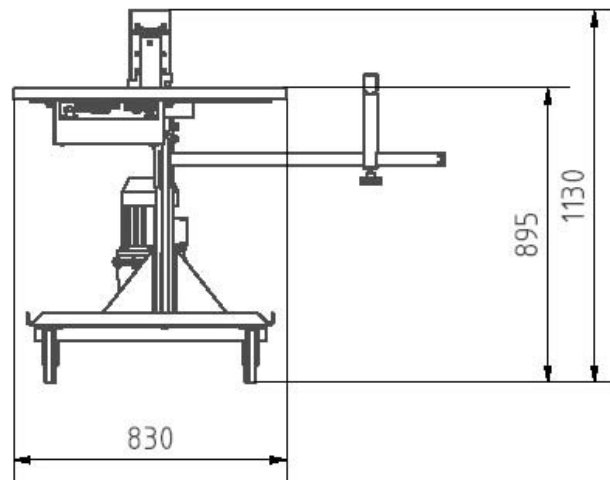

BGD-5eco top

